

PRODUCT INFORMATION PACKET

Model No: 056H17T15526

Catalog No: Y280

0.50 HP Variable Speed Motor, 3 phase, 1800 RPM, 230/460 V, 56C Frame, TENV
1000:1 with Encoder Motors





Nameplate Specifications

Output HP	0.50 Hp	Output KW	0.37 kW
Frequency	60 Hz	Voltage	230/460 V
Current	1.6/0.80 A	Speed	1725 rpm
Service Factor	1	Phase	3
Efficiency	80 %	Power Factor	72
Duty	Continuous	Insulation Class	H
Design Code	INV	KVA Code	L
Frame	56C	Enclosure	Totally Enclosed Non Ventilated
Thermal Protection	No	Ambient Temperature	40 °C
Drive End Bearing Size	6203	Opp Drive End Bearing Size	6203
UL	Recognized	CSA	Y
CE	Y	IP Code	43

Technical Specifications

Electrical Type	Squirrel Cage Inverter Duty	Starting Method	Inverter Only
Poles	4	Rotation	Reversible
Resistance Main	36.2 Ohms	Mounting	Bolt-on Base
Motor Orientation	Horizontal	Drive End Bearing	Ball
Opp Drive End Bearing	Ball	Frame Material	Rolled Steel
Shaft Type	NEMA 56	Overall Length	13.74 in
Frame Length	7.06 in	Shaft Diameter	0.625 in
Shaft Extension	2.06 in	Assembly/Box Mounting	F1 ONLY
Connection Drawing	A-EE7308	Outline Drawing	A-107388-706

This is an uncontrolled document once printed or downloaded and is subject to change without notice. Date Created:18/06/2020

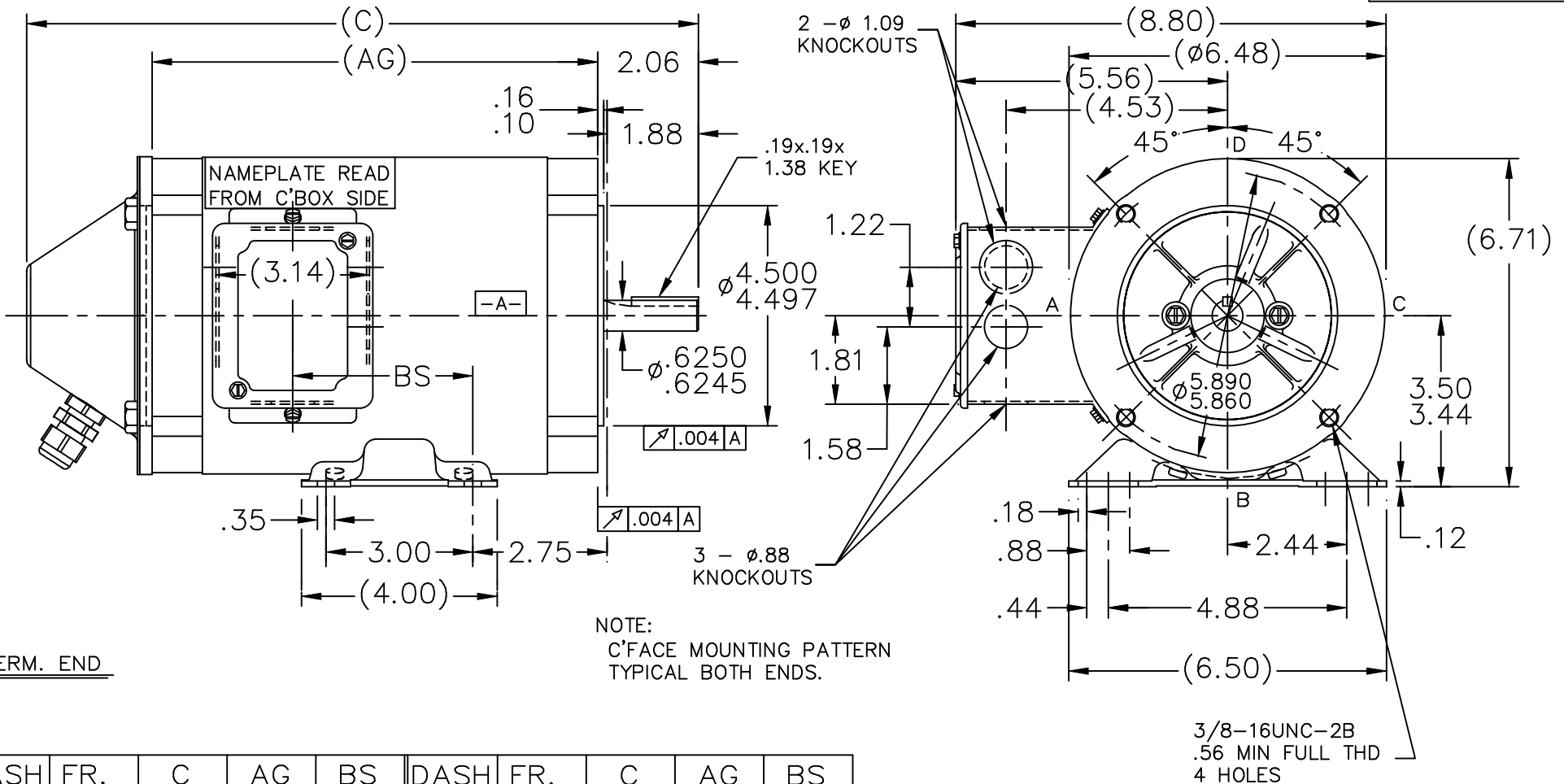

NOTE:
C'FACE MOUNTING PATTERN
TYPICAL BOTH ENDS.

TERM. END

DASH	FR.	C	AG	BS	DASH	FR.	C	AG	BS
					756	56-75	14.24	9.61	4.25
606	56-60	12.74	8.11	2.75	806	56-80	14.74	10.11	4.75
656	56-65	13.24	8.61	3.25	856	56-85	15.24	10.61	5.25
706	56-70	13.74	9.11	3.75					

NOTES:
1. REMOVABLE BASE
2. CONDUIT BOX CAN BE ROTATED 180°.

				TOLERANCES UNLESS SPECIFIED			DRAWN JJB 03-26-2008							
				DEC.	INCHES		CHK ML 03-27-2008							
				.X	±.1		APPD GK 03-27-2008							
				.XX	±.03		SCALE 5=16							
				.XXX	±.005		REF 104043A							
				.XXXX	±.0005	TITLE	OUTLINE - HS 20 TACH.							
						56 FR. - TENV - BB - DBL. C'FACE								
						MAT'L.								
						FINISH								
NO.	REVISION			BY & DATE		CHK	ANG	±7'30"	PREV	ME080078				
THIS DRAWING IN DESIGN AND DETAIL IS OUR PROPERTY AND MUST NOT BE USED EXCEPT IN CONNECTION WITH OUR WORK ALL RIGHTS OF DESIGN AND INVENTION ARE RESERVED THIS IS AN ELECTRONICALLY GENERATED DOCUMENT - DO NOT SCALE THIS PRINT						RFP	CAD FILE 107388			SIZE	DRAWING NO.	PAGE	OF	REV.
						DIST	WP		A	107388				

EE7308

THREE PHASE
DUAL VOLTAGE MOTOR



VIEW OF TERMINAL END

REF.
WINDING DIAGRAM

T8Y, T2Y, T2BL, T4BX, T2EC, T2G
T6BZ, T2B, T6BL, T4AV, T6B, T4B

OPTIONAL CORD
CONNECTION

L1 — WHITE
L2 — RED
L3 — BLACK

NO.	REVISION	BY & DATE	CHK	ANG	TOLERANCES UNLESS SPECIFIED		FINISH	DRAWN RM 11/20/1990				
					DEC.	INCHES						
5	CHG TO REGAL LOGO	SL 09/10/2015	AB					CHK ML 11/21/1990				
4	REVISED IEC NOTATIONS	MSG 11/15/2011	CMN	.X	±.1			APPD SAS 04/24/2003				
3	ADDED IEC NOTATIONS... (U1), (V1) ETC. MU95194	MSG 5/10/2010	MJS	.XX	±.02		TITLE CONNECTION DIAGRAM	SCALE 1=1				
2	ADDED THE OPTIONAL CORD CONNECTION MU46318	RDH 04/24/2003	DRS	.XXX	±.005		3Ø - DUAL VOLTAGE MOTOR	REF				
1	REDRAWN	RM 11/20/1990		.XXXX	±.0005		MAT'L.	FMF				
					±7'30"			PREV				
THIS DRAWING IN DESIGN AND DETAIL IS OUR PROPERTY AND MUST NOT BE USED EXCEPT IN CONNECTION WITH OUR WORK ALL RIGHTS OF DESIGN AND INVENTION ARE RESERVED THIS IS AN ELECTRONICALLY GENERATED DOCUMENT - DO NOT SCALE THIS PRINT							RFP	CAD FILE ee7308	SIZE A	DRAWING NO. EE7308	PAGE OF 5	REV. 5
							DIST WP					



Regal Beloit America, Inc.

CERTIFICATION DATA SHEET

Model#: 56H17T15526 A WINDING#: ZT471 F 4
 CONN. DIAGRAM: A-EE7308 ASSEMBLY: F1 ONLY
 OUTLINE: A-107388-706

TYPICAL MOTOR PERFORMANCE DATA

HP	KW	SYNC. RPM	F.L. RPM	FRAME	ENCLOSURE	KVA CODE	DESIGN
1/2	.37	1800	1725	56C	TENV	L	INV

PH	Hz	VOLTS	FL AMPS	START TYPE	DUTY	INSL	S.F	AMB°C	ELEVATION
3	60	230/460	1.6/8	INVERTER ONLY	CONTINUOUS	H1	1.0	40	3300

FULL LOAD EFF: 80	3/4 LOAD EFF: 78.5	1/2 LOAD EFF: 75	GTD. EFF	ELEC. TYPE	NO LOAD AMPS
FULL LOAD PF: 72	3/4 LOAD PF: 63	1/2 LOAD PF: 50.5	77.5	SQ CAGE INV DUTY	1 / .5

F.L. TORQUE	LOCKED ROTOR AMPS	L.R. TORQUE	B.D. TORQUE	F.L. RISE°C
1.52 LB-FT	11.2 / 5.6	4.6 LB-FT 303	5.8 LB-FT 382	55

SOUND PRESSURE @ 3 FT.	SOUND POWER	ROTOR WK^2	MAX. WK^2	SAFE STALL TIME	STARTS /HOUR	APPROX. MOTOR WGT
62 dBA	72 dBA	0.056 LB-FT^2	0 LB-FT^2	0 SEC.	0	25 LBS.

EQUIVALENT WYE CKT.PARAMETERS (OHMS PER PHASE)

R1	R2	X1	X2	XM
22.30668	17.028	24.123	18.1632	532.9764
RM	ZREF	XR	TD	TD0
20263.32	567.6	1.5	0.0054	0.885

*** SUPPLEMENTAL INFORMATION ***

DE BRACKET TYPE	ODE BRACKET TYPE	MOUNT TYPE	ORIENTATION	SEVERE DUTY	HAZARDOUS LOCATION	DRIP COVER	SCREENS	PAINT
C-FACE	ENCODER	BOLT-ON	HORIZONTAL	FALSE	NONE	FALSE	NONE	BLACK (POWDER)

BEARINGS		GREASE	SHAFT TYPE	SPECIAL DE	SPECIAL ODE	SHAFT MATERIAL	FRAME MATERIAL
DE	OPE						
BALL	BALL	POLYREX EM	STANDARD 56	NONE	NONE	1144 STRESSPROOF (C-223)	ROLLED STEEL
6203	6203						

THERMO-PROTECTORS				THERMISTORS	CONTROL	SPACE /n HEATERS
THERMOSTATS	PROTECTORS	WDG RTDs	BRG RTDs			
NONE	NOT	NONE	NONE	NONE	FALSE	NONE VOLTS

If Inverter equals NONE, contact factory for further information

INVERTER TORQUE: CONSTANT 1000:1
INV. HP SPEED RANGE: 2.0 X BASE SPEED
ENCODER: REGAL SUPPLIED - REGAL MOUNT DYNAPAR HS20
MS CONNECTOR 1024 PPR
BRAKE: NONE NONE

*
N
O
T
E
S
*

NONE	P/N	NONE	
NONE	NONE		
NONE FT-LB	NONE V	NONE Hz	

DATE: 06/28/2017 01:07:04 AM
FORM 3531 REV.3 02/07/99
** Subject to change without notice.

